

# LARGE SCALE METROLOGY IN AEROSPACE ASSEMBLY

**Jody Muelaner**  
The University of Bath  
J.E.Muelaner@bath.ac.uk

**Paul G Maropoulos**  
The University of Bath  
P.G.Maropoulos@bath.ac.uk  
(Paper no. 52)

## ABSTRACT

The paper presents a review of the principles and state of the art in instrumentation used to make large scale measurements within aerospace assembly. The ability to measure large artefacts accurately is a key enabling technology to improve quality and facilitate automation. Particular emphasis is placed on issues of uncertainty with the importance of acceptance criteria explained and verification standards compared and discussed. The fundamental technologies deployed are explained including laser trackers, indoor GPS and photogrammetry. Commercially available systems are compared in terms of uncertainty, range and deployment related issues.

## KEYWORDS

Metrology, Large Volume, Uncertainty, Laser Tracker, iGPS, Photogrammetry

## 1. INTRODUCTION

The assembly of large aerospace structures is characterized by a reliance on monolithic jigs and high levels of manually intensive reworking, fettling and drilling operations. In simple terms the process is to bring together large flexible components and secure them to a rigid jig which controls the shape of the emerging structure. Any mismatch between components is detected through the use of slip gauges and other manual inspection techniques. Components are shimmed or fettled to ensure that interface tolerances are maintained. Holes are then drilled through the components and they are fastened together. This has been summarized as, "Place, clamp, fasten and release" (Pickett et al, 1999). A generic aerospace assembly is shown in more detail in Figure 1.

Assembly may account for as much as 40% of the total cost of manufacturing an airframe due largely to the labour and quality issues inherent to drilling thousands of holes per aircraft (Bullen 1997). Approximately 5% of the total manufacturing cost of an aircraft (Rooks 2005) or 10% of the airframe (Burley et al, 1999) is related to the use of fixed tooling

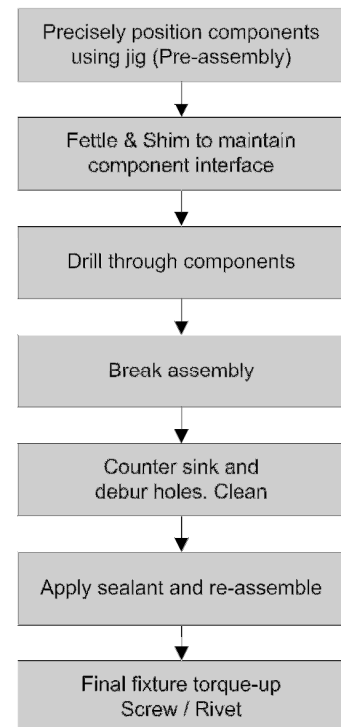

Figure 1 – Generic Assembly Process

while reworking also represents a significant proportion of the total cost of aircraft (Curran et al, 2002).

Large scale frameless metrology systems such as laser and vision based technologies have the potential to overcome many problems in aerospace assembly by enabling flexible automation systems. Large scale reconfigurable tooling has been successfully demonstrated using the inherent accuracy of machine tools to place fixtures which are then locked in place (Stone 2004). The use of new metrology technologies makes the reconfiguring of tooling in other applications a practical and affordable proposition (Burley, Odi et al. 1999) eliminating the requirement for fixed jigs. There is also the potential to facilitate the automation of inspection (Buckingham et al, 2007), fettling (Webb and Eastwood 2004) and drilling (Rooks 2001).

A major factor impeding the introduction of automation is the difficulty in making accurate measurements and tool placements at the scale required for commercial aircraft production. Large scale metrology systems address these issues.

## 2. UNCERTAINTY IN RELATION TO PART ACCEPTANCE

A common mistake made by those not familiar with the principles of metrology is to assume that the resolution of an instrument is the same as its accuracy. This can be easily understood with the example of a tape measure. The resolution of the tape is 1 mm and a user might assume that the accuracy is therefore  $\pm 0.5$  mm. When measuring horizontally with the tape unsupported the accuracy will be considerably worse than this since sag and stretch will be highly dependent on the tension in the tape.

In Figure 2 a measurement is being made between two brackets. The dimension is 1,500 mm with a tolerance of  $\pm 5$  mm. The graduations on the tape show the distance to be 1,497 mm and so it could be assumed that the part is within tolerance. In actual fact the sag in the tape has taken up 3 mm and so the actual distance between the brackets is 1,494 mm – out of tolerance!

If the tolerance for a part gives a minimum and a maximum value then when the part is measured using a given instrument, allowance must be made for that instrument's uncertainty. The expanded uncertainty, at a given confidence level, for the instrument is added to the minimum value to give a minimum acceptance value. Similarly the expanded uncertainty is subtracted from the maximum value to give a maximum acceptance value. When the part is measured the reading must be within the range of

the acceptance values in order to say that the part is within the tolerance at the given confidence level (BSI 1999).

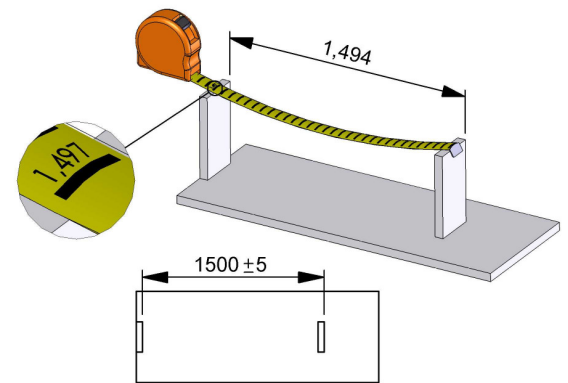

Figure 2 – Tape Measure Example

We can say that there are five possible scenarios when making a measurement as illustrated graphically in Figure 3.

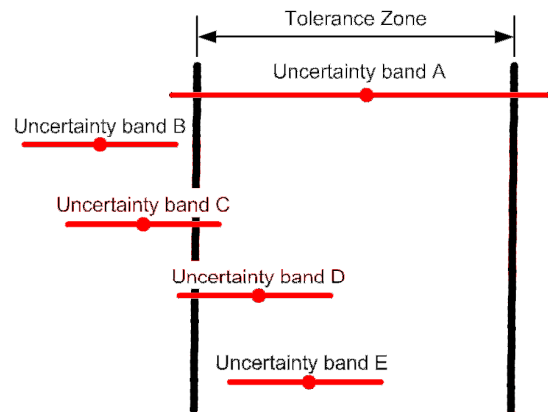

Figure 3 – Possible Interactions between Tolerance Zone and Uncertainty Band

- A. The uncertainty of the instrument is greater than the tolerance of the part and so it will never be possible to determine whether the part is within tolerance.
- B. The uncertainty of the instrument is less than the tolerance of the part. The reading shows the part to be sufficiently out of tolerance that there is no overlap between the tolerance zone and the uncertainty band. We can therefore state with confidence that the part is out of tolerance.
- C. The uncertainty of the instrument is less than the tolerance of the part. The reading shows the part to be out of tolerance but there is overlap between the tolerance zone and the uncertainty band. The part may be in tolerance but must be rejected.
- D. The uncertainty of the instrument is less than the tolerance of the part. The reading shows the part to be in tolerance but there is

overlap between the tolerance zone and the uncertainty band. The part is probably in tolerance but we can not state this with confidence and therefore it must be rejected.

- E. The uncertainty of the instrument is less than the tolerance of the part. The reading shows the part to be sufficiently within the tolerance that there is no overlap between the tolerance zone and the uncertainty band. We can therefore state with confidence that the part is in tolerance. This is the only case where the part should be accepted.

If we return to the example of the tape measure and say that the uncertainty in the measurement is  $\pm 4$  mm at a 95% confidence level. Since the dimension 1,500 mm has a tolerance of  $\pm 5$  mm the acceptance criteria is that the measured value lies between 1,499 mm and 1,501 mm. The measurement of 1,497 mm would therefore fail even though it initially appears to be within tolerance (condition D).

These issues are important to remember when using a digital instrument which may have a resolution of 0.1  $\mu\text{m}$  but an uncertainty of  $\pm 50$   $\mu\text{m}$ !

### 3. VERIFICATION STANDARDS

A number of publications are summarized which have relevance to the verification of large scale metrology instruments. Although the standards and papers reviewed cover a number of different instruments there is a great deal of common ground between them.

The measurement of calibrated lengths is a basic principle of maintaining traceability of the measurements made with an instrument back to some reference standard.

Isolation of sub-systems is an application of the principle of decomposing sources of error. In all systems which use a probe there is an attempt to isolate the error due to the probe and quantify this error independently. A possible source of probe error is a deviation from sphericity. Similarly most of the literature reviewed encouraged the isolation of individual encoder errors in initial tests.

In addition to testing sub-systems in isolation the literature also encourages testing the combined effect of the system as a whole. Standard tests are not able to establish traceability of all measurements that it is possible for complex equipment to make. It is therefore important that standard tests are supplemented by tests which more closely resemble the measurement tasks to be carried out.

Tests should be carried out in accordance with normal operation of the instrument as recommended by the manufacturer.

In the standards studied simple decision rules were used to determine conformance or non-conformance with the expected performance.

#### ISO 10360-2:2002

The ISO 10360 (BSI 2002) acceptance and re-verification tests are a well established standard for coordinate measuring machines (CMMs); it is directly applicable only to conventional gantry based CMMs using contact probing and operating in the discrete-point probing mode. Error is divided into probing error and error of indication of size measurement.

Probe error is determined by making 25 point measurements on the surface of a known sphere and computing the deviation of measured points from the Gaussian associated sphere.

The error of indication of size measurement is the primary measure of the accuracy of a CMM. Five different calibrated lengths are placed in seven different locations and/or positions and measured three times in each position for a total of 105 measurements. The longest length should be at least 66% of the longest diagonal within the measuring volume. The standard does not state the orientations in which the measurements should be taken, however the NPL guide to CMM verification (Flack 2001) does suggest that the seven different locations might include some of the four cross diagonals, the three in plane diagonals and the lines nominally parallel to an axis.

#### ASME B89.4.19.

The ASME B89 (ASME 2006) standard details verification procedures specific to 'Spherical Coordinate Measurement Systems' used as industrial measurement tools such as laser trackers and laser radar. The low level generic tests measuring calibrated lengths that are detailed in this standard should be supplemented by tests which closely mirror the operating conditions.

The standard specifies two types of tests:-

- System tests: These measure a reference length (at least 2.3 m) located perpendicular to the radial direction. This engages both the ranging and angle measuring subsystems. Since the ranging ability of laser trackers is generally more accurate than the angle measuring ability, these tests will primarily test the angle measuring capability.
- Ranging Tests: These measure reference lengths located along the radial direction, isolating the ranging subsystem. Alignment should be sufficiently accurate for the cosine error to be negligible.

Different types of acceptable reference length are described including a calibrated artefact capable of

holding retroreflectors and two independent structures with the distance between reflector nests measured by a distance measuring device. If a calibrated artefact is used its length should be adjusted for thermal expansion.

It is advised that the SMR is positioned with the same orientation relative to the measurement beam in order to minimise errors due to the SMR.

System tests are carried out a number of times with measurements in a number of orientations; horizontal, vertical, right diagonal and left diagonal.

For each of these configurations measurements are taken at different ranges and angles. Generally two different ranges are used and four different angles for each range. For the horizontal configuration an additional position at very close range is added. Three measurements are taken at each position.

Calculated uncertainties in length measurement are plotted against range and a least squares fit of a straight line is found, resulting in a stated uncertainty which is linearly dependent on range.

Appendices deal with related subjects such as documenting the traceability of the reference length, determining the geometric errors in spherically mounted retroreflectors (SMR) and quantifying errors caused by environmental factors that influence the refractive index of light. These errors can be divided into radial errors due to changes in the speed of light and transverse errors due to beam refraction.

## ISO 17123

ISO 17123 is of relevance to theodolite type instruments; Part 1 (ISO 2002) covers the underlying theory of field tests for geodetic and surveying instruments while Part 3 (ISO 2001) deals specifically with theodolites.

These tests are intended to be field verifications of the suitability of a particular instrument for the “immediate task at hand... They are not proposed as tests for acceptance or performance evaluations...” (ISO 2002) Unfortunately there does not appear to be a standard available which does deal with the performance evaluation of theodolites and manufacturers’ even state that their total stations’ inspection certificates are compliant with ISO 17123 (Leica 2006).

Precision of theodolites is expressed in terms of experimental standard deviation and there is no information given as to how to verify the actual angles that are formed by the instrument and a pair of targets. This standard therefore does not maintain the principle of traceability and in fact only measures the repeatability of instruments and not the accuracy.

## 4. PRINCIPLES OF GENERIC INSTRUMENT TYPES

A brief explanation of how some common instruments work is given.

### LASER-BASED SPHERICAL COORDINATE MEASUREMENT SYSTEMS

Laser-based spherical coordinate measurement systems combine a laser distance measurement with two angle measurements to give coordinate measurements in 3 dimensions such instruments include laser trackers (Lau et al, 1985) and laser radar. The main body of the instrument emits a laser from a gimbaled head; in the case of a laser tracker a spherically mounted retroreflector (SMR) is then used to reflect the laser back to the unit allowing the distance to be measured. In the case of laser radar the light is scattered off the object being measured and the scattered light is detected at the instrument. The remainder of this discussion will concentrate on laser trackers; however the same principles apply to laser radar with the difference being that scattered light is used to give a non-contact measurement system.

Sensors detect the position of the returned laser and provide feedback to sensors in the gimbal in order to track the reflector so that as the reflector moves so does the gimbaled head; keeping the laser aimed at the reflector. Encoders in the gimbal measure the azimuth and elevation angle to the reflector.

In this way the laser tracker is able to measure the coordinates to the center of the SMR. The SMR has a known calibrated radius and so can be used as a probe with which objects can be measured.

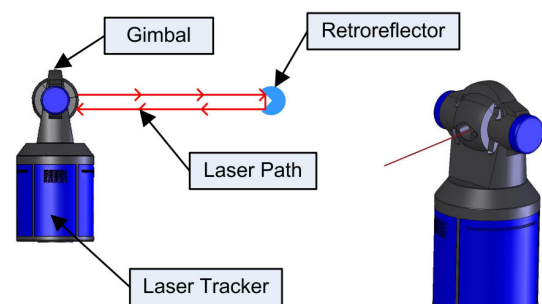

Figure 4 – Laser Tracker

There are two different approaches to distance measurement used by laser trackers. The original and still the most accurate method is to measure the displacement from a known reference using a fringe counting interferometer. The technique, first developed in an attempt to detect the ether

(Michelson and Morley 1887), became practical for measurement with the creation of the laser.

Figure 5 illustrates the principle of an interferometer as applied to range measurements within a laser tracker. Laser light is emitted from a source and passes through a half silvered mirror acting as a beam splitter. One beam then reflects off a reference mirror while the other reflects off a measurement mirror in the SMR. The two beams are recombined at the beam splitter and directed towards a detector.

Since the two beams have traveled different distances there is likely to be a difference in phase, if the difference in distance is an exact multiple of the wavelength of the light then the two beams will be in phase and interference between the waves will be constructive. If the distance differs by half a wavelength then the interference will be destructive. As the measurement mirror moves so the two beams will move in and out of phase resulting in pulses of light separated by darkness, known as fringes. By counting these fringes the displacement can be calculated in terms of the wavelength of the light.

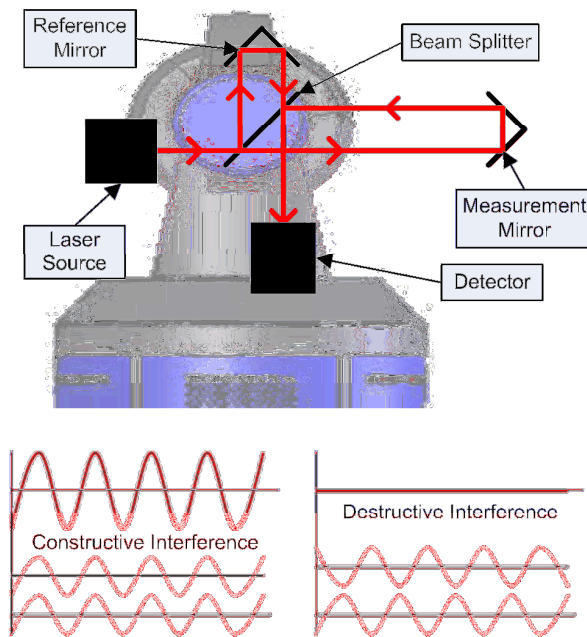

Figure 5 – Operation of Interferometer in Laser Tracker

The disadvantage of interferometric measurements is that all measurements must be taken continuously without breaking the laser beam. This can make measurement in a production environment difficult and time consuming.

The second approach to distance measurement is known as absolute distance measurement (ADM). This gives a distance rather than a displacement and so the laser beam can be broken and then picked up by the SMR at a new location. There are many possible ADM technologies with the most obvious being time of flight calculations of a pulse of laser

light. Time of flight depends on timer accuracy and due to the very high velocity of light cannot give accurate measurements over the relatively short distances under consideration.

The ADM technology employed by Leica for use in their laser trackers is phase detection of a modulated polarization plane (Kyle 1999). This technique compares the phase of a reference signal with that of a measurement signal.

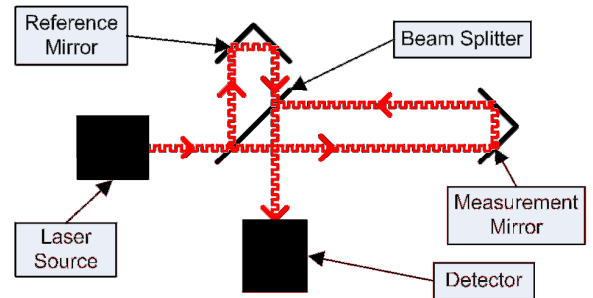

Figure 6 – Phase Modulated Distance Measurement

It is somewhat similar to interferometry with the fundamental difference that a modulated signal is used rather than the waveform of the light its-self. This allows the frequency (and therefore also the wavelength) to be adjusted until the reference signal and the measurement signal are in-phase. The frequency is then increased until the next point where both signals are in-phase so that

$$d = \frac{\lambda_1}{2} N_1 \quad (1)$$

$$d = \frac{\lambda_2}{2} N_2 \quad (2)$$

where  $d$  is the distance being measured,  $\lambda_1$  and  $\lambda_2$  are the two wave lengths when the signals are in-phase and  $N_1$  and  $N_2$  are the corresponding integer numbers of wavelengths over the length  $d$ .

Since the two points where the signals were in phase were successive

$$N_2 = N_1 + 1 \quad (3)$$

The fundamental equations can be used to convert from wavelength to frequency.

$$\lambda_1 = \frac{c}{f_1} \quad (4)$$

$$\lambda_2 = \frac{c}{f_2} \quad (5)$$

where  $c$  is the speed of light and  $f_1$  and  $f_2$  are the respective frequencies.

Substituting equations ( 4 ) and ( 5 ) into ( 1 ) and ( 2 ) and rearranging gives

$$N_1 = \frac{2 \cdot d \cdot f_1}{c} \quad (6)$$

$$N_2 = \frac{2 \cdot d \cdot f_2}{c} \quad (7)$$

Finally substituting equations ( 6 ) and ( 7 ) into ( 3 ) gives

$$d = \frac{c}{2(f_2 - f_1)} \quad (8)$$

Other ADM technologies include intensity modulation which has demonstrated a resolution of 1  $\mu\text{m}$  at 5 m range (Fujima et al, 1998) and frequency scanning interferometry which has been applied to large multilateration networks within CERN (Coe et al, 2004).

## INDOOR GPS

The Indoor GPS system (iGPS) uses a number of transmitters placed around the working volume to fix the position of a single sensor. Communication from transmitter to sensor is one-way and so it is possible to have a large number of sensors simultaneously receiving signals and detecting their position. In this sense it is similar to the NAVSTAR GPS system where signals from a number of satellites allow any number of GPS receivers to fix their position. In every other aspect the function of iGPS is fundamentally different from NAVSTAR GPS. iGPS is a proprietary technology owned by Metris.

Each transmitter acts as a rotary-laser automatic theodolite (R-LAT) providing the sensor with optical signals which allow the azimuth and elevation angle from the transmitter to the sensor to be calculated. Angular data from at least two transmitters allows the position of the sensor to be fixed in 3 dimensions using triangulation provided that the transmitter positions are known. The normal setup procedure for an iGPS network includes a bundle adjustment (Triggs et al, 1999) in order to determine the relative positions of the transmitters. A system with more than two transmitters will be able to apply some form of least squares fitting to the redundant data to reduce the uncertainty of the coordinate measurements.

An R-LAT is made up of two parts; a transmitter and a sensor. The transmitter consists of a stationary body and a rotating head. The rotating head sweeps two fanned laser beams through the working volume, while the stationary body delivers a strobe

with a single pulse for every other revolution of the head. The fanned laser beams are inclined at 30 degrees to the horizontal and offset by 90 degrees to one another (Hedges et al, 2003) as shown in Figure 7.

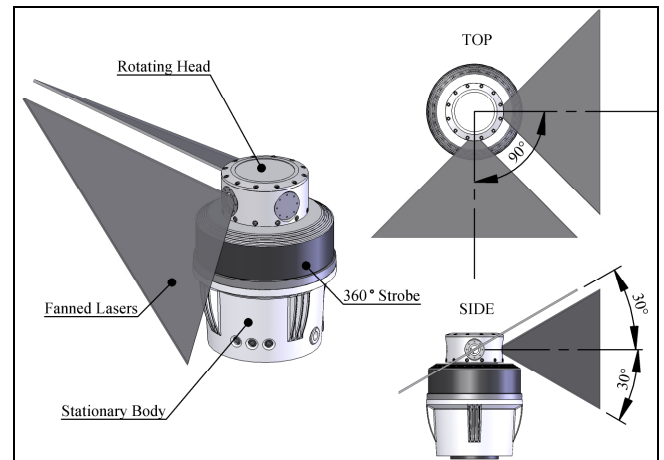

Figure 7 - Main Components of Transmitter

The sensor is able to detect both the fanned laser beams as they sweep past and the pulse of light from the strobe. There is no other form of communication between the transmitter and receiver. Azimuth and elevation angles are calculated using the timing differences between pulses of light reaching the sensor. Each transmitter is configured to rotate at a slightly different speed; typically approximately 3,000 rev/min. It is this difference in speed which allows the system to differentiate between the signals from different transmitters (Hedges, Takagi et al. 2003).

A novel aspect of the iGPS system is the use of the R-LATs, described above, which have the following advantages:-

1. The one-way communication allows a theoretically unlimited number of sensors to simultaneously detect signals from a single network of transmitters.
2. Since the transmitters do not track the sensor no re-aiming is required if line of sight is broken.
3. The sensor is able to detect signals from a wide range of angles.
4. The cumulative effect of 2 and 3 is that, assuming there is sufficient redundancy in the network, a sensor can move around various line of sight obstructions losing and regaining connection to transmitters with relative ease.

The flexibility of operation facilitated by the system has considerable potential for use within the aerospace sector and other large scale manufacturing sectors. iGPS has been demonstrated in various applications such as jigless assembly of aircraft structures (Sharke 2003), positioning of robots and the alignment of laser projection (Sell

2005). The multiple sensor architecture is particularly useful in assembly since it is no longer necessary to have a base component precisely located by tooling within a known reference frame. The multiple sensor approach allows the position of each component to be tracked individually providing feedback to flexible automation systems.

## PHOTOGRAMMETRY

Photogrammetry involves the measurement of 3-dimensional objects by comparing two or more 2-dimensional images taken from different positions. Common points must be identified on the images allowing the line of sight from each point to each camera position to be constructed. Assuming the camera positions are known then the positions of the points can be calculated by simple triangulation.

Typically a bundle adjustment (Triggs, Mclauchlan et al. 1999) is carried out in order to determine the relative positions of the transmitters. A system with more than two transmitters will be able to apply some form of least squares fitting to the redundant data to reduce the uncertainty of the coordinate measurements.

The identification of common points on images from different cameras usually requires some form of target to be placed on the artifact. This may be a physical target such as disc of brightly colored material or a projected target such as a laser dot.

## 5. CLASSIFICATION OF METROLOGY INSTRUMENTS

Instruments may be classified according to a number of operational parameters and qualities. The consideration of these is important in specifying which type of instrument is suitable for a particular measurement operation. Important factors are:-

- Scale (Volumetric Coverage)
- Accuracy
- Measurement Frequency
- Sequential or area scanning measurements
- Informational Richness (1D, 2D points, 3D points, 6DOF tracking, 2D shape, 3D surface)
- Centralized or distributed
- Information transfer (gantry, flexible arm, single line of sight, ultrasonic etc)
- Contact or non-contact
- Software support (instrument interface and simulation)
- Operating environment

The first level of classification is often based on the scale at which measurements can be taken and in this paper only large scale measurements greater than one meter will be considered. Accuracy is clearly important in metrology and is generally inversely proportional to the scale of the

measurements being taken. Measurement frequency is a difficult quantity to specify since most instruments are capable of relatively high frequencies but a single measurement has a low accuracy. Generally averages of a number of measurements are used to substantially increase accuracy. The maximum accuracy and maximum frequency will never be achieved simultaneously.

Closely related to frequency is whether the instrument measures multiple points sequentially or through area scanning. Most instruments will measure each point in sequence but those based on photographic techniques will be able to image all points in an area simultaneously.

Informational richness is used here to describe the type of measurements being taken. Traditional instruments are usually one-dimensional (1D); a micrometer or calipers are able to measure a single length. There are also state of the art instruments in this category such as 'laser rail' interferometers. The next level of informational richness is two-dimensional (2D) part detection, these are devices able to detect a sensor or locate a probe on a surface or perpendicular to a surface. 2D shape recognition is able to measure holes and other features on sheet parts. Three-dimensional (3D) point measurement is the measurement of discrete positions in space. These systems generally use some form of probe possibly in the form of an optical target and are actually measuring the center of this probe. Six degree of freedom (6DOF) systems are able to measure both the coordinates and the rotation of a sensor or target; these systems are particularly useful for providing feedback to automation. Finally 3D surface characterization is able to detect the complete form of an object and digitize this, essentially a CAD model can be created from a physical artifact. Generally these systems will require line of sight so a number of observation points will be required to digitize a complete object.

Instruments may be centralized meaning that a single instrument such as a laser tracker is used to make measurements or distributed with a number of stations required to find the coordinates of a point such as a network of theodolites. It is also possible to use a number of centralized instruments to form a distributed network in order to improve accuracy, extend the measurement network beyond the line of sight of a single instrument or to improve the information such as using a number of 1D instruments to make 3D coordinate measurements.

Information transfer is used here to describe the transfer of information from the measured point to the instrument datum or from one measurement to the next. This definition encompasses other classification schemes such as framed or frameless instruments but also allows for more detailed

description. For example information on the location of a point relative to an instrument's internal datum may be transferred by physical access using a gantry mounted probe or a flexible arm mounted probe. Alternatively the transfer may take place through single or multiple laser lines of sight. In either the physical access or the laser example the information can only realistically propagate through a fluid (the air) or vacuum. There are many other possibilities such as magnetic flux, x-rays, ultrasound etc which are able to propagate through other media. This property of an instrument is likely to require some qualitative description.

Closely related to the means of information transfer is whether measurements are taken through physical contact or by non-contact methods. Contact may be made through a physically attached probe as in a gantry coordinate measurement machine (CMM) or through a remote probe such as the reflector used with a laser tracker. Alternatively truly non-contact measurements may be taken by detecting laser light scattered off the part, this may be supported by a gantry CMM or a remote laser radar system.

Clearly the classification of metrology instruments is a complex subject and a simple flat hierarchy cannot fully characterize a group of instruments. Furthermore many instruments can operate in more than one mode and therefore fit into multiple categories for a particular property.

Rather than lose a great deal of information and create a misleading representation by attempting to fit the instruments to a particular flat taxonomy, or design a complex ontology, the approach suggested here is to tabulate the details of each property for each instrument configuration. This then forms a data base which can be filtered according to the required properties for a given measurement application.

## 6. COMPARISON OF AVAILABLE SYSTEMS

Four instruments will be considered here to give an example of how a catalogue of instruments can be created to facilitate selection. Figure 8 shows accuracy against range for these instruments. The accuracy data was obtained direct from the manufacturers of the K610 (Metris 2005), MV224 (Metris 2008), Faro Tracker (Faro 2007), V-Stars (Geodetic Systems 2005a) (Geodetic Systems 2005b) and Leica Tracker (Leica 2008).

There are a large number of instruments available and many different configurations for each making a comprehensive coverage of these well beyond the scope of this paper. What is presented here is a generic methodology which may be applied to populate a database with instruments for specific applications.

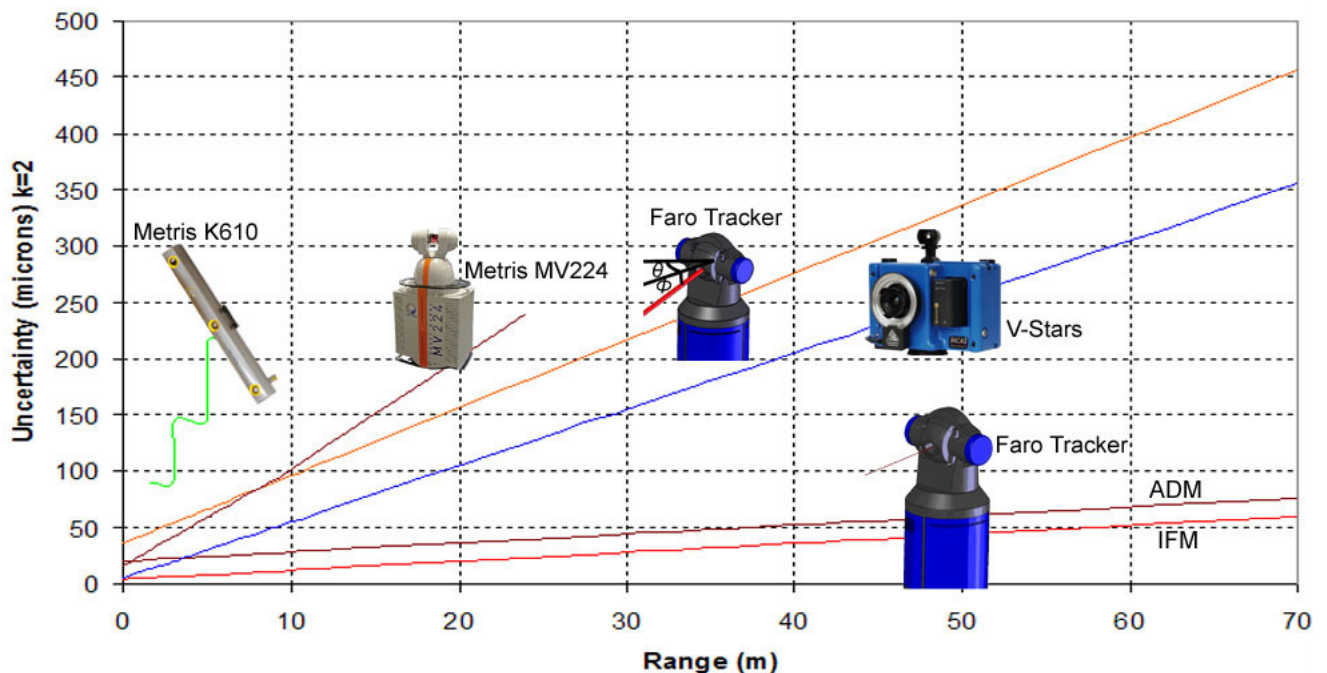

Figure 8 : Comparison of Commercial Metrology Instruments



Table 1: Example of tabulated instrument specifications

Instrument	Configuration	Accuracy $\mu\text{m}$	Fixed Targets ?	DOF	Centralized or Distributed	Part Interface	Information Transfer
Faro Laser Tracker	Single station	70	No	3	Centralized	Contact	Single line of sight
	Sequential ADM Multilateration 4 station	33	Yes	3	Distributed	Contact	4 lines of sight from wide range of angles
	Sequential IFM Multilateration 4 station	17	Yes	3	Distributed	Contact	4 lines of sight from wide range of angles
	ADM Multilateration 4 station	23	No	3	Distributed	Contact	4 lines of sight from wide range of angles
	IMF Length Measurement	7	Yes	1	Centralized	Contact	Single line of sight
Metris Laser Radar	Surface Scan	102	No	3	Centralized	Non-Contact	Single line of sight
	Tooling ball - single station	102	Yes	3	Centralized	Contact	Single line of sight
	Tooling ball - multilateration - 4 station	102	Yes	3	Distributed	Contact	4 lines of sight from wide range of angles
Metris K610	Space Probe Measurement	145	No	5	Centralized	Contact	3 lines of sight from narrow range of angles
V-Stars	Physical Targets on Part	25	Yes	3	Distributed	Contact	2 Lines of sight from wide range of angles
	Laser projected targets	25	No	3	Distributed	Non-Contact	2 Lines of sight from wide range of angles

Table 1 presents an example of the type of information which might be tabulated for each instrument configuration. In this example the accuracy relates to the measurement of a 3 m part at a range of 4 m, a more sophisticated database might generate accuracies for instruments dynamically using a function for each instrument. A more complete database would also include additional columns detailing properties such the time required to make measurements and the operating conditions of the instrument (temperature, pressure and humidity range).

## 7. CONCLUSIONS

A small selection of the wide range of large volume metrology instruments is presented and only a small number of the properties of each have been considered. There are different strategies available for a given measurement operation and the selection of the optimum instrument is a complex task. The first step is to clearly identify the problem in terms of the attributes detailed in section 2. The use of graphical comparisons such as Figure 8 and tables of attributes can then simplify the selection process.

## 8. ACKNOWLEDGMENTS

The work has been carried out as part of the EPSRC, IdMRC at the Mechanical Engineering Department of the University of Bath, under grant No. EP/E00184X/1. The authors wish to thank Alistair Forbes and Ben Hughes of NPL and Rodger

Holden of Metris who have provided support and technical advice.

## REFERENCES

- ASME (2006). Performance Evaluation of Laser-Based Spherical Coordinate Measurement Systems. [B89.4.19](#).
- BSI (1999). Geometrical Product Specifications (GPS) — Inspection by measurement of workpieces and measuring equipment — Part 1: Decision rules for proving conformance or non-conformance with specifications. [BS EN ISO 14253-1:1999](#).
- BSI (2002). Geometrical Product Specifications (GPS) - Acceptance and reverification tests for coordinate measuring machines (CMM) - Part 2: CMMs used for measuring size. [BS EN ISO 10360-2](#).
- Buckingham, R., Chitrakaran, V., Conkie, R., Ferguson, G., Graham, A., Lazell, A., Lichon, M., Parry, N., Pollard, F., Kayani, A., Redman, M., Summers, M. and Green, B., "Snake-Arm Robots: A New Approach to Aircraft Assembly", *AeroTech Congress & Exhibition*, Los Angeles, California, 2007
- Bullen, G. N. "The Mechanization / Automation of Major Aircraft Assembly Tools." *Production and Inventory Management Journal*:1997 84-87
- Burley, G., Odi, R., Naing, S., Williamson, A. and Corbett, J., "Jigless Aerospace Manufacture - The Enabling Technologies", *Aerospace Manufacturing Technology Conference & Exposition*, Bellevue, Washington, 1999
- Coe, P. A., Howell, D. F. and Nickerson, R. B. "Frequency scanning interferometry in ATLAS: Remote, multiple, simultaneous and precise

- distance measurements in a hostile environment." *MEASUREMENT SCIENCE AND TECHNOLOGY* 15(11):2004 2175-2187
- Curran, R., Kundu, A., Raghunathan, S. and McFadden, R. "Impact of aerodynamic surface tolerance on aircraft cost driver." *Proc Instn Mech Engrs Part G: J Aerospace Engineering* 216:2002 29-39
- Faro (2007). Faro Laser Tracker Xi. **2008**.
- Flack, D. "Measurement Good Practice Guide No. 42: CMM Verification" National Physical Laboratory 2001,
- Fujima, I., Iwasaki, S. and Seta, K. "High-resolution distance meter using optical intensity modulation at 28 GHz." *Measurement Science & Technology* 9(7):1998 1049-1052
- Geodetic Systems (2005a). Inca 3 - Picture Perfect Measurements. **2008**.
- Geodetic Systems (2005b). Pro-Spot - True non-contact measurement. **2008**.
- Hedges, T. M., Takagi, H., Pr-Latt, T. and Sobel, M. J. (2003). Position Measurement System and Method Using Cone Math Calibration. U. S. Patent, Arc Second.
- ISO (2001). Optics and optical instruments - Field procedures for testing geodetic and surveying instruments - Part 3: Theodolites. 17123-3.
- ISO (2002). Optics and optical instruments - Field procedures for testing geodetic and surveying instruments - Part 1: Theory. 17123-1.
- Kyle, S. "Operational features of the Leica laser tracker." *IEE Colloquium (Digest)*(154):1999 15-20
- Lau, K., Hocken, R. and Haight, W. "AUTOMATIC LASER TRACKING INTERFEROMETER SYSTEM FOR ROBOT METEROLOGY", Interlaken, Switz, 1985,
- Leica (2006). Leica Industrial Theodolites & Total Stations. **2008**.
- Leica (2008). PCMM System Specifications: Leica Absolute Tracker and Leica T-Products. **2008**.
- Metris (2005). K610-CMM. **2008**.
- Metris. (2008). "Metris - Laser Radar - Automated, large volume inspection." Retrieved 07/04/08, 2008, from [http://www.metris.com/large\\_volume\\_metrology/laser\\_radar/](http://www.metris.com/large_volume_metrology/laser_radar/).
- Michelson, A. A. and Morley, E. W. "On The Relative Motion of the Earth and the Luminiferous Ether." *The American Journal of Science* 34(203):1887
- Pickett, N., Eastwood, S., Webb, P., Gindy, N., Vaughan, D. and Moore, J., "A Framework to Support Component Design in Jigless Manufacturing", *Aerospace Manufacturing Technology Conference & Exposition*, Bellevue, Washington, 1999
- Rooks, B. "Automatic wing box assembly developments." *Industrial Robot: An International Journal* 28(4):2001 297-301
- Rooks, B. "Assembly in aerospace features at IEE seminar." *Assembly Automation* 25(2):2005 108-111
- Sell, C. "On the right lines." *Engineer* 293(7680):2005 30
- Sharke, P. "Measuring across space and time." *Mechanical Engineering* 125(1):2003 48
- Stone, P. R. "Reconfigurable Fixturing". *Aerospace Manufacturing and Automated Fastening Conference and Exhibition*, St. Louis, MS, USA, 2004,
- Triggs, B., Mclauchlan, P., Hartley, R. and Fitzgibbon, A., "Bundle Adjustment - A Modern Synthesis", *Vision Algorithms: Theory and Practice, International Workshop on Vision Algorithms*, Corfu, Greece, 1999
- Webb, P. and Eastwood, S. J. "An evaluation of the T12 manufacturing system for the machining of airframe subassemblies." *Proc. Instn Mech. Engrs Part B: J. Engineering Manufacture* 218:2004 819-826