

# INTEGRATED DIMENSIONAL VARIATION MANAGEMENT IN THE DIGITAL FACTORY

**Jody Muelaner**  
The University of Bath  
jody@muelaner.com

**Prof Paul G Maropoulos**  
The University of Bath  
p.g.maropoulos@bath.ac.uk

## ABSTRACT

This paper describes how dimensional variation management could be integrated throughout design, manufacture and verification, to improve quality while reducing cycle times and manufacturing cost in the Digital Factory environment. Initially variation analysis is used to optimize tolerances during product and tooling design and also results in the creation of a simplified representation of product key characteristics. This simplified representation can then be used to carry out measurability analysis and process simulation. The link established between the variation analysis model and measurement processes can subsequently be used throughout the production process to automatically update the variation analysis model in real time with measurement data. This 'live' simulation of variation during manufacture will allow early detection of quality issues and facilitate autonomous measurement assisted processes such as predictive shimming.

A study is described showing how these principles can be demonstrated using commercially available software combined with a number of prototype applications operating as discrete modules. The commercially available modules include Catia/Delmia for product and process design, 3DCS for variation analysis and Spatial Analyzer for measurement simulation. Prototype modules are used to carry out measurability analysis and instrument selection. Realizing the full potential of Metrology in the Digital Factory will require that these modules are integrated and software architecture to facilitate this is described. Crucially this integration must facilitate the use of real-time metrology data describing the emerging assembly to update the digital model.

## KEYWORDS

Variation analysis, digital factory, measurability

## 1. INTRODUCTION

In its initial form the Digital Factory may be seen as the simulation of every detail of the manufacturing process before it happens allowing better planning (Dwyer 1999). At a more advanced stage the simulation can be used, not only during the planning phase, but also to enhance the control of processes on the production floor (Kuhn 2006).

The importance of design for manufacture has been well established (Womack et al, 1990; Fabricius 1994; Maropoulos et al, 2000) it has also been suggested that design for measurability should be a part of this (Muelaner et al, 2009). Additionally

process modelling has been shown to contribute significantly to process planning (Maropoulos, Yao et al. 2000; Maropoulos et al, 2003). Previous work has laid out a generic framework for measurement planning (Cai et al, 2008) and presented prototype instrument selection and measurability analysis software (Muelaner et al, 2010).

This paper extends this work to show how simulations of product variation created during the product design phase can be integrated with measurement simulation. This will initially give an enhanced understanding of product variation and verification.

At later stages in the product life cycle the use of metrology to control processes, enable flexible processes and manage component interfaces, will be enhanced through the use of these integrated simulations of product variation and measurement uncertainty.

The manufacture of high quality products requires close tolerances to be achieved. This is a particular issue for large composite structures such as the next generation of passenger aircraft and off-shore wind turbines. The conventional methods for maintaining close tolerances over large structures involve the use of jigs to control the external form of the structure combined with manual shimming and fettling processes to maintain the interface tolerances between components. These methods are time consuming and dependent on highly skilled manual operations. The conventional methods, in their current form, are also not able to improve on current external form tolerances due to the limitations of environmental factors such as the thermal expansion of jigs. This means that improvements in aerodynamic profiles required for increased efficiencies can not be realized.

As an example of a conventional assembly process components are loaded into a precisely aligned assembly jig, gaps between the components are then carefully mapped using slip gauges and shims are produced to these measurements. The components are removed from the jig, reassembled with the shims in place and the measurement of gaps using slip gauges is repeated. It may be necessary to repeat the shimming process due to the inaccuracy inherent in such a manual process. Once the gaps have been filled to within the required tolerances the components are drilled through and then again removed from the jig so that sealant can be applied. They are then finally assembled. This process is

illustrated in

### Conventional Assembly

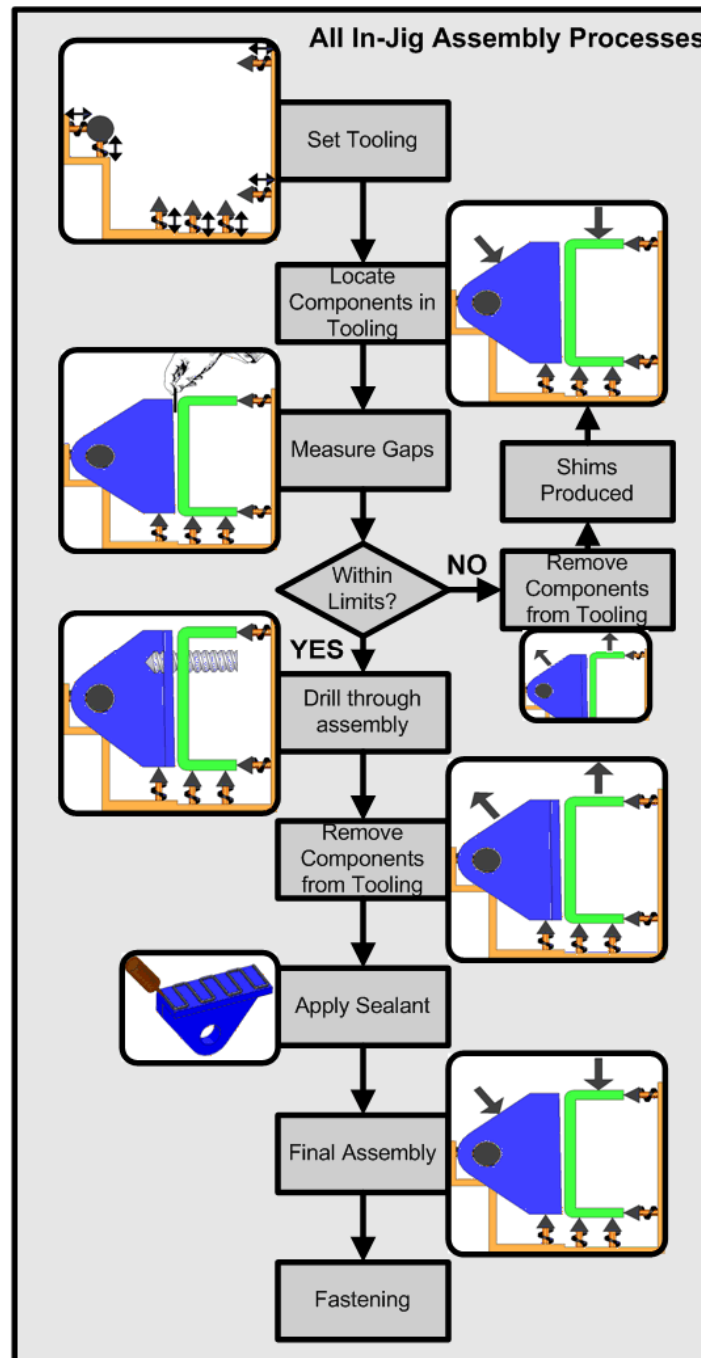

Figure 1.

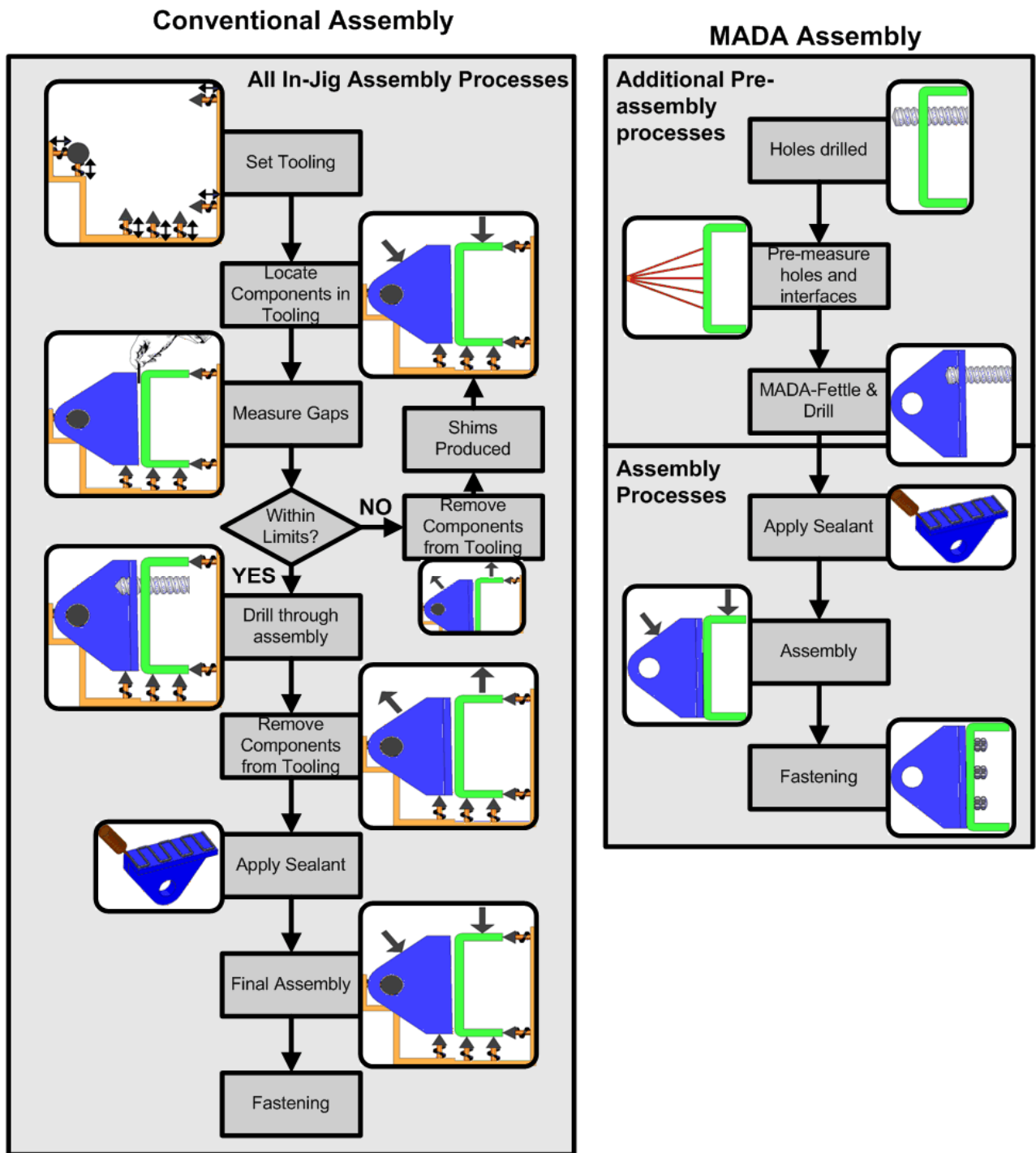

Figure 1: Conventional Aerospace Assembly Process

The conventional approach described above is not suitable to achieving the cost and process time reductions required for the increased rates of production forecast for products such as off-shore wind turbines and next generation single aisle passenger aircraft.

Alternative methods of maintaining tolerances are in development. These generally also rely on jigs to control the external form of structures with alternative processes used to maintain the interface tolerances between components. These approaches

have been generically described as Measurement Assisted Assembly (MAA) (Kayani and Jamshidi 2007). MAA includes processes such as predictive shimming (Kayani and Gray 2009) and fettling where interface components are first measured and this measurement data is then used to produce shim or fettle interfacing components.

Although these approaches reduce the level of manual rework required at the assembly stage they still generally require measurements to be taken in

the assembly jig since they are not associated with models able to predict the form of components within the jig. They also do nothing to address the limitations inherent in using large assembly jigs, which are subject to thermal expansion, to control aerodynamic form.

Determinate Assembly (DA) has been demonstrated as a solution to reliance on jigs (Stone 2004) although in many applications it is not possible to achieve the required component tolerances. Measurement Assisted Determinate Assembly (MADA) has therefore been suggested as a way to implement DA for large assemblies with tight tolerances (Muelaner and Maropoulos 2010).

An integrated approach to the design of products and planning, monitoring, and control of processes is required to design products; which minimise the need for dimensional control during manufacture while maximising the achievable aerodynamic profile accuracy and other key characteristics.

This approach must consider the propagation of variation through the product assembly during the early stages of design ensuring that tolerance requirements do not put unnecessary demands on products and that the key characteristics of the assembly can be practically measured.

The design of processes must take into account the variability in outputs from forming, assembly and measurement processes. It is therefore necessary to have models of machine tools, robots and measurement instruments which include the variability and uncertainty of these operations.

## 2. VARIATION MODELLING USING SIMPLIFIED REPRESENTATIONS OF KEY CHARACTERISTICS

Geometric Dimensioning and Tolerancing (GD&T), the standard for Geometrical Product Specification (GPS) provides a continuous definition that ALL points on a surface are within a specified zone; of course this can never be fully verified. In reality representative discrete coordinate measurements are typically taken to verify that a surface is within tolerance. In a similar way a point based model can be used to represent continuous geometry for the purpose of simulating product variability.

It is logical that the points defined for simulation purposes should also be used for measurement. It is important that random measurement locations are also used however. This is because if consistent points are used for measurement then a process may become optimized for these points meaning that they are no longer representative of the variability of a surface as a whole.

Rules are required to streamline the process of deciding how many control points are required to

verify given features. Such features should include surfaces, holes, pins etc. It will then be possible for the designer to work in a system where he specifies the intent of his design and this is coded as both GD&T for a standards based approach as well as being discretised to a point based model for variation analysis, measurement planning etc.

Use of a point based model has the advantage of facilitating relatively simple calculation of the propagation of variability within an assembly. It also gives greatly reduced data file sizes. For example a complex aircraft component such as a composite wing cover could have a data size of 100 Mb when stored as a CATIA file. If this component were characterized quite rigorously with a point placed every 10 mm the total data required would still be reduced to less than 5 MB. More detail on this calculation is given in Table 1. It is therefore clear that even where large profile tolerances are represented using reasonably detailed point based representations considerable reductions in data file sizes are possible.

**Table 1: Data required for Point based Model**

Total surface area for controlled surfaces	60	m <sup>2</sup>
Grid spacing	10	mm
Total control points	600,000	
Measurement Resolution	1	µm
Max Scale for Measurements	100	m
Data required per point measurement	4	Bytes
Data required including data label	8	Bytes
Total data required to describe component	4.58	MB

### 2.1. DEFINING COMPONENT INTERFACES

Points representing two components can be used to simulate the interface between those components. Further inputs will however be required from the designer in determining exactly how components will interface with each other. This can be understood by considering a component with two pins, one of which has a shoulder, and a plate with one hole and a slot, as shown in Figure 2. The assembly condition can be simulated by calculating the distances between points and applying translations and rotations to bring the movable plate part into its assembled condition with the target pin part.

Different assumptions can be made regarding the details of how the pins and shoulders will constrain the movement of the plate. For example if it is assumed that the pin in a hole is relatively tight, and will therefore control rotation about the x and z

axes, then a simple '3-2-1' fit can be used. In this case three points on each of the target and the movable parts are used to simulate the assembly interface conditions and the following transformations are carried out:-

- **Translate component to make C1 coincident with T1.** The distances in x, y and z between points C1 and T1 are calculated. These distances are then simply subtracted from all of the points defining the component geometry.
- **Rotate component about x and y (with origin at T1) so that C2 lies on the line through T1 and T2.** These rotations can be carried out one at a time. The angles between the lines C1-C2 and T1-T2 are first calculated in the x-y and y-z planes and the corresponding rotations then carried out by applying a rotation matrix.
- Rotate component about z (with origin at T1) so that C3 lies on the plane through T1, T2 and T3.

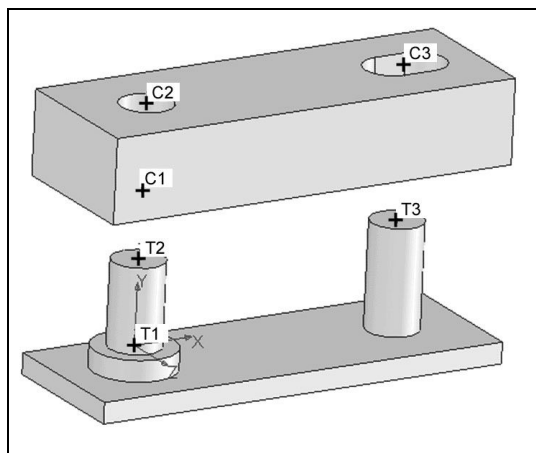

Figure 2: Pin - Shoulder - Slot Location Example

It should be pointed out that this type of 3-2-1 fit is called a 'Three-Point Move' in 3DCS while the term '3-2-1 Move' is used to describe a different type of move using 6 points on each component!

It should be noted that different assumptions about how the assembly will locate will lead to different methods of fitting the points. For example if it is assumed that the pin in a hole is relatively loose but that the plate is clamped down onto the shoulder so that it is the shoulder that controls rotation about x and z then a more complex form of '3-2-1' is required, sometimes referred to as a 'step-plane move' which involves the following steps:-

- The part is located onto the shoulder controlling translation in y and rotation about both x and z. Points C1, C2 and C3 are moved into contact with a plane through T1, T2 and T3.
  - C1 translated to T1
  - Rotate about x and z
- The part is then located onto the pin in one translation

Other methods of fitting are also possible, for example a least-squares best fit could be used although it is this unlikely to accurately simulate real world conditions.

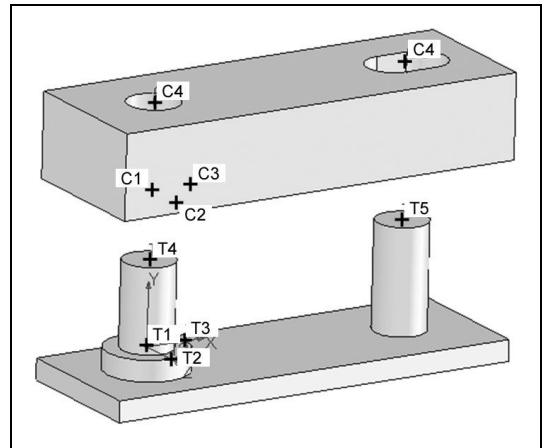

Figure 3: Shoulder - Pin - Slot Location Example

If it is not known whether the pin or the shoulder will control rotation about x and z then it is possible to apply a number of different fitting algorithms with the transformation of the movable component taking place in small iterations. It is then possible to apply some test condition such as measuring the distance between points to check which contact condition will come into play first and then allow this to position the component. By applying this type of test it is possible to run a simulation in which, due to component variability, the contact conditions between components vary from assembly to assembly.

The requirement for a rules based translation of GD&T into a point based model of component geometry was described above. Ultimately the CAD system should also read the component interfaces from the CAD assembly model and automatically convert these into coordinate transformations with iterative solutions to correctly simulate interface conditions. Initially it is unlikely that such an approach could be applied to the full range of interfaces seen in complex aerospace assemblies. The simulation of standard connections such as the examples shown with pins and holes should however be automated.

## 2.2. RUNNING MONTE CARLO SIMULATION OF THE SIMPLIFIED GEOMETRY

Once a simplified, point based, representation of parts has been created and the interface conditions between the parts in an assembly has been defined, it is then possible to simulate variability in the assembly using the Monte Carlo method. Based on the GD&T definitions or Statistical Process Control (SPC) data, randomly generated errors are added to each point, simulating component variability.

Additional randomly generated errors may also be added to some of the points in order to simulate the assembly variability due to ‘float’ between, for example, an oversized hole or slot and an undersized pin. The complete simulation process for the Pin-Shoulder-Slot example is shown in Figure 4.

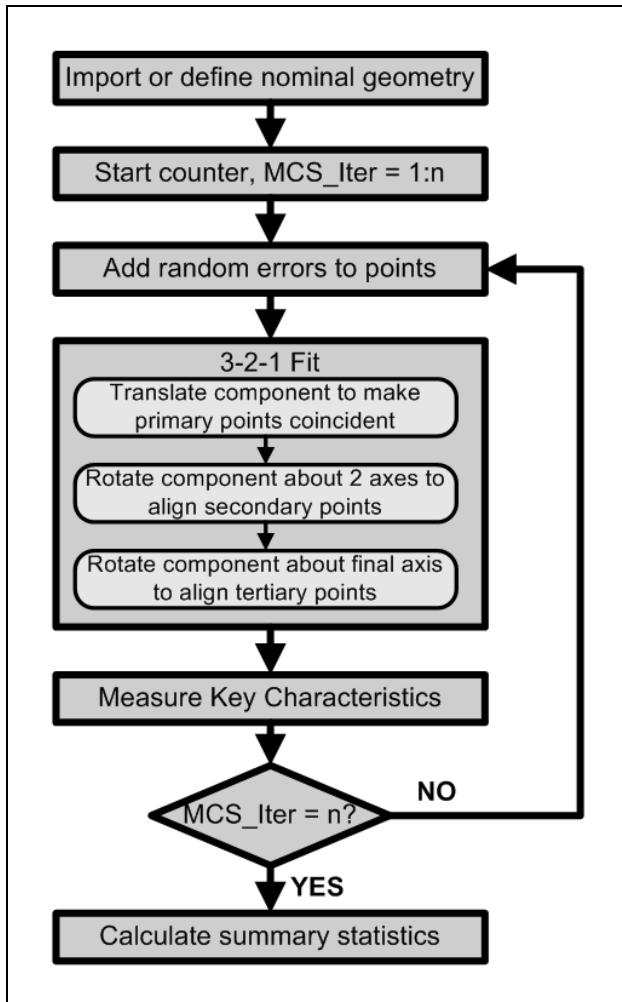

Figure 4: Simulation of Pin-Shoulder-Slot Assembly using 3-2-1 Fit

### 3. INTEGRATION OF DIMENSIONAL VARIATION MANAGEMENT ACROSS THE DIGITAL FACTORY

The variation models described above can be used to simulate product variability in order to optimize tolerances during product and tooling design. The simplified, point based, representation of product key characteristics which was created for the

variation model can then be used to carry out measurability analysis and process simulation. For example measurement simulation (Calkins 2002; New River Kinematics 2007; Muelaner, Cai et al. 2010) can be used to establish the uncertainty of measurement for each of the points representing the product geometry. Simulation of component forming operations may also be carried out at this stage to obtain improved estimates of actual component variability.

Improved estimates of component variability and measurement uncertainty can then be fed back into the variation model to obtain improved simulation results. The simulation of product variation is therefore an iterative process with the results refined a number of times as the product and process is developed.

Since the measurement process planning has been based on the point based model originally created for variation simulation, it is also possible to feed ‘live’ measurement results back into the simulation. This allows the actual as-built condition of an emerging assembly to be simulated. It is never possible to know exactly what the as-built condition is since there is always a degree of uncertainty of measurement. The uncertainty of measurement therefore replaces component variability in the model to allow improved estimates of the final build to be generated as the build process progresses.

This ‘live’ simulation of variation during manufacture will allow early detection of quality issues and corrective actions to be taken. It will also facilitate measurement assisted processes such as predictive shimming and MADA, discussed above.

This integration of dimensional variation management can be demonstrated using commercially available software combined with a number of prototype applications operating as discrete modules. The commercially available modules might include Catia/Delmia for product and process design, 3DCS for variation analysis and Spatial Analyzer for measurement simulation. Prototype modules are used to carry out measurability analysis and instrument selection.

The complete integrated dimensional variation management process is summarized in Figure 5.

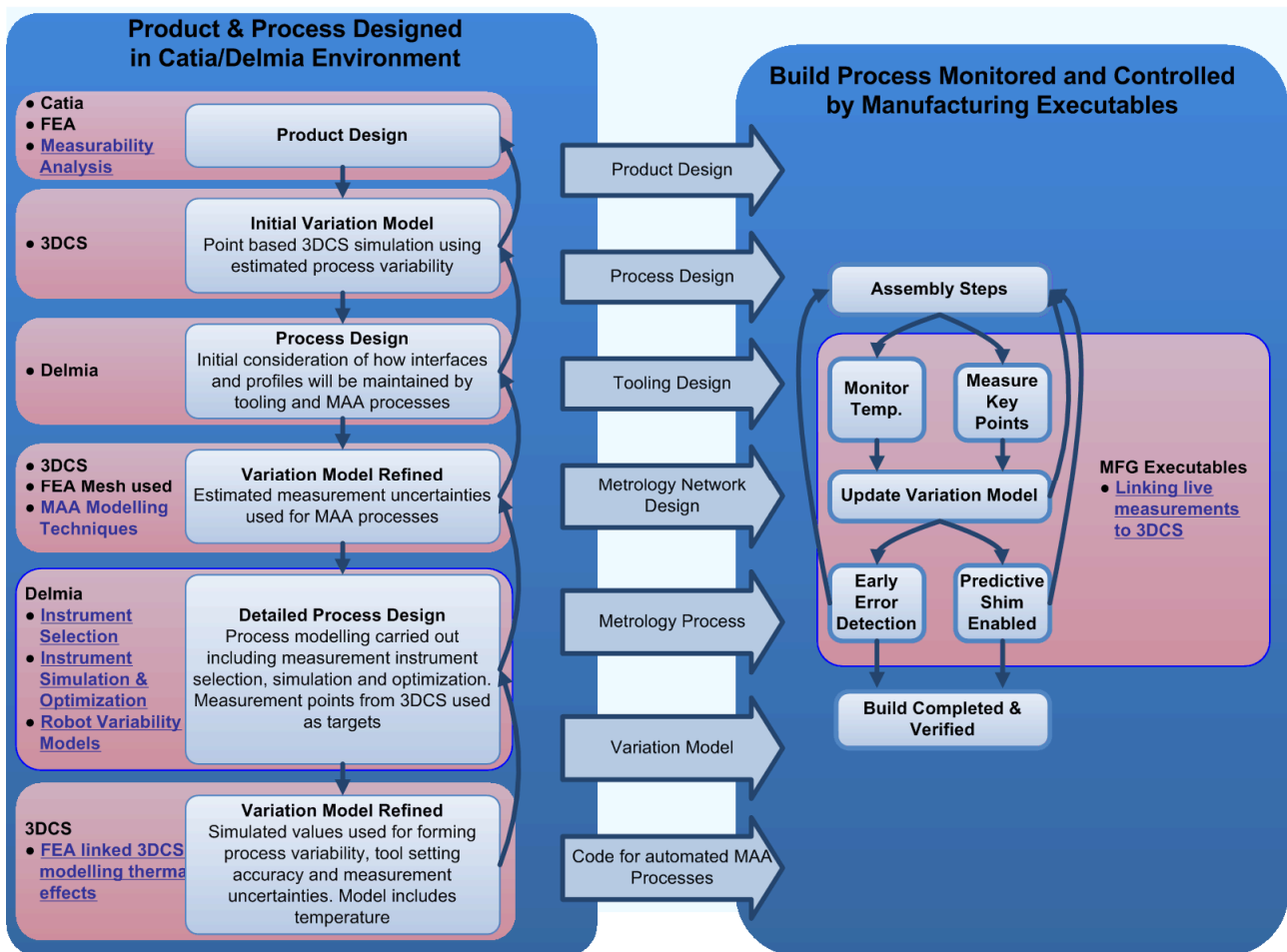

Figure 5: Generic Overview of Dimensional Variation Management

#### 4. CONCLUSIONS

Rules are required to streamline the process of deciding how many control points are required to verify and/or simulate given features. Such features should include surfaces, holes, pins etc. It will then be possible for the designer to work in a system where he specifies the intent of his design and this is coded as both GD&T for a standards based approach as well as being discretised to a point based model for variation analysis, measurement planning etc.

Models of machine tools, robots and measurement instruments are required which include the variability and uncertainty of these operations. These will provide inputs to the variation simulation for assemblies.

Realizing the full potential of integrated dimensional variation management will require that these modules are integrated and software architecture to facilitate this is described. Crucially this integration must facilitate the use of real-time metrology data describing the emerging assembly to update the digital model.

#### REFERENCES

- Cai, B., Guo, Y., Jamshidi, J. and Maropoulos, P. G., "Measurability Analysis Of Large Volume Metrology Process Model For Early Design", *5th International Conference on Digital Enterprise Technology*, Nantes, France, 2008
- Calkins, J. M. (2002). Quantifying Coordinate Uncertainty Fields in Coupled Spatial Measurement Systems *Mechanical Engineering*. Blacksburg, Virginia Polytechnic Institute and State University. **PhD**: 226.
- Dwyer, J. "Simulation - the digital factory." *Manufacturing Computer Solutions* 5(3):1999 48-50
- Fabricius, F. "Seven step procedure for design for manufacture." *World Class Design to Manufacture* 1(2):1994 23-30
- Kayani, A. and Gray, I. (2009). Shim for Arrangement Against a Structural Component and a Method of Making a Shim, Airbus UK Ltd.

Kayani, A. and Jamshidi, J., "Measurement Assisted Assembly For Large Volume Aircraft Wing Structures", *4th International Conference on Digital Enterprise Technology*, Bath, United Kingdom, 2007

Kuhn, W. "Digital factory - Simulation enhancing the product and production engineering process", Monterey, CA, United states, 2006,

Maropoulos, P. G., Bramall, D. G. and McKay, K. R. "Assessing the manufacturability of early product designs using aggregate process models." *Proceedings of the Institution of Mechanical Engineers, Part B: Journal of Engineering Manufacture* 217(9):2003 1203-1214

Maropoulos, P. G., Yao, Z., Bradley, H. D. and Paramor, K. Y. G. "Integrated design and planning environment for welding Part 1: product modelling." *Journal of Materials Processing Technology* 107(1-3):2000 3-8

Muelaner, J. E., Cai, B. and Maropoulos, P. G., "Large Volume Metrology Instrument Selection And Measurability Analysis", *6th International Conference on Digital Enterprise Technology*, Hong Kong, 2009

Muelaner, J. E., Cai, B. and Maropoulos, P. G. "Large Volume Metrology Instrument Selection and Measurability Analysis." *IMechE, Part B: J. Engineering Manufacture* 224:2010 853-868

Muelaner, J. E. and Maropoulos, P. G., "Design for Measurement Assisted Determinate Assembly (MADA) of Large Composite Structures", *CMSC*, Reno, Nevada, 2010

New River Kinematics (2007). SpatialAnalyzer.

Stone, P. R. "Reconfigurable Fixturing". *Aerospace Manufacturing and Automated Fastening Conference and Exhibition*, St. Louis, MS, USA, 2004,

Womack, J. P., Jones, D. T. and Roos, D. "The Machine that Changed the World" Rawson Associates New York 1990,